

Flash Dryers

Explosion Suppression Systems

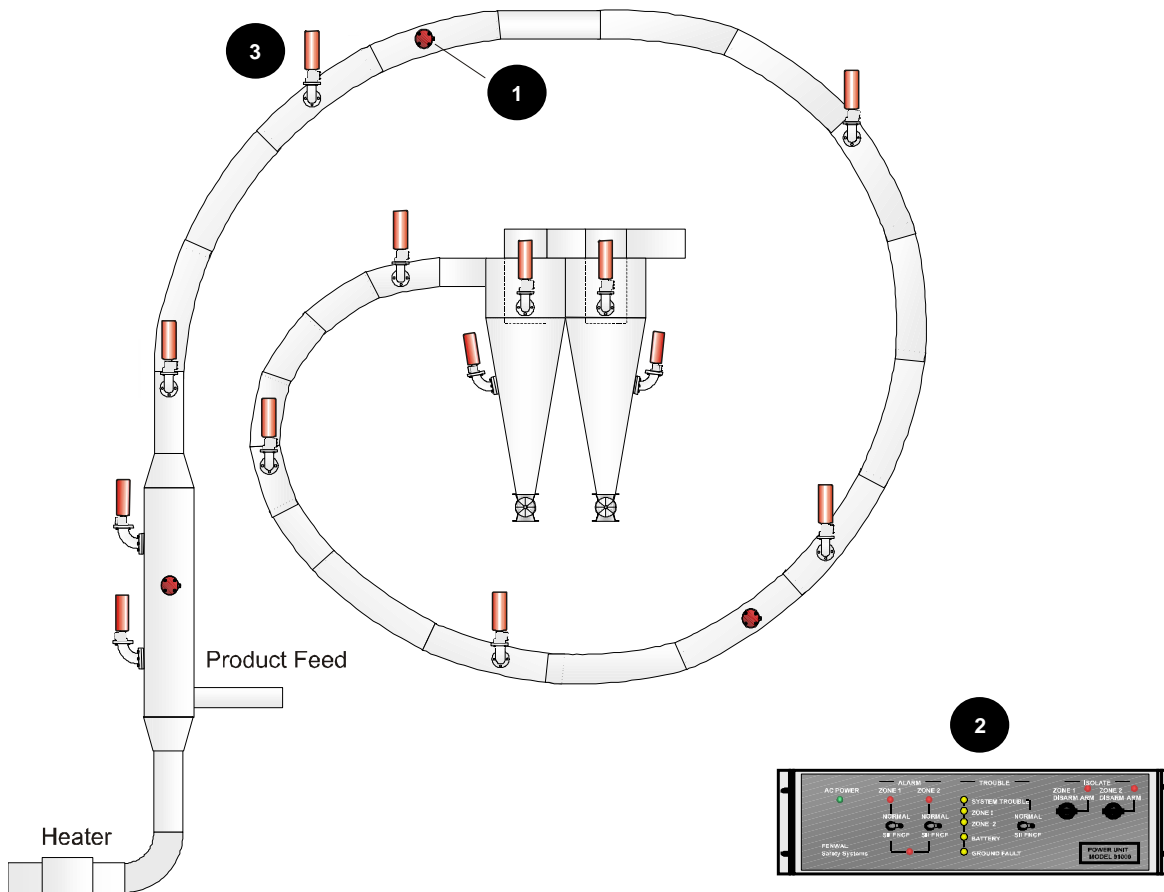

Application

Flash dryers are used to dry wetted materials such as cornstarch. The material to be dried is metered into a hot airstream generated by an oil or gas-fired heater. The product dries as it is transported along the dryer ducting. This ducting terminates in a bank of cyclones or other separators which remove the dried product from the airstream. Secondary separators such as dust collectors may also be used.

System Components

- ① **Pressure Detector**
- ② **Two Zone Control Panel**
- ③ **HRD Suppressor**

Hazard

If the material being handled by a process is combustible, then the dust it generates is likely to be explosive. In flash drying systems, the material being processed becomes more sensitive to ignition as it passes down the dryer and loses its moisture. The minimum ignition energy of the dried product can be low enough to present the threat of ignition by static discharge. Additionally, material adhering to the walls of the dryer can absorb enough energy to self-ignite. The resulting deflagration generates high flame speeds and rapidly produces destructive pressures due to the pressure piling effects of the duct geometry.

Protection System Considerations

Protection systems for flash dryers must provide adequate suppressant concentration throughout the process. Additionally, if cyclones are employed, smooth internal walls are needed to maintain air separation efficiency.

IEP Technologies suppression systems accommodate this by not having protrusions into the process and by incorporating flush spreader assemblies for suppressant dispersal, where needed.

Protection System Description

In an explosion suppression system for flash dryers, explosion pressure detectors are mounted at several locations along the dryer duct and on each of the air separation vessels. These detect the pressure excursion from an impending explosion and signal a control panel. The control unit triggers high rate discharge suppressors while simultaneously shutting down the process. Suppressors are designed to rapidly discharge and quench the fireball before maximum explosion pressures are created and mitigate flame propagation. Similarly, suppressors mounted on the air separators quench the fireball and reduce the risk of explosion propagation to interconnected equipment.

Typical Installation Details

Extinguisher Flush Spreader

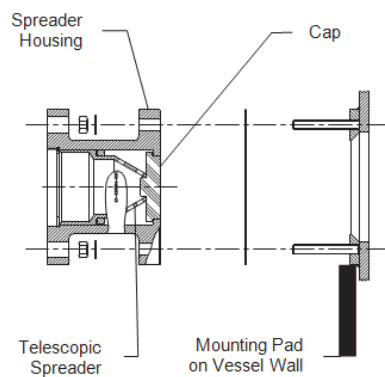

Dynamic Pressure Detector

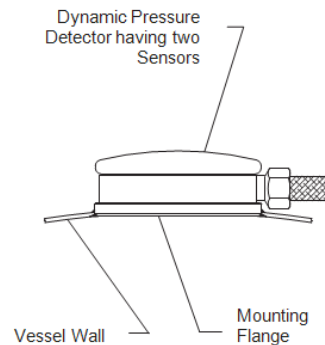

Contact Information

For additional information, please contact one of the following locations:

IEP Technologies

United States: Tel: +1 (855) 793 8407

United Kingdom: Tel: +44(0) 1242 283 060

Switzerland: Tel: +41 (0) 62 207 10 10

Germany: Tel: +49 (0) 2102 5889 0